

# Indexing Table

# ZR 20

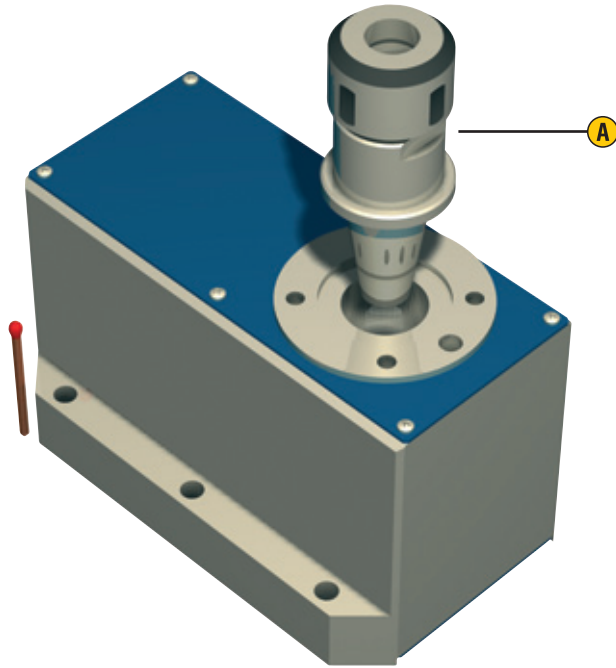

## Features

- play-less timing belt drive with stepping motor
- reduction 1:20
- shaft with through hole Ø 15
- reception flange with internal cone SK 20
- weight: 2,1 kg

### Options:

- CNC control via Sub D

**A** Collets Fitting SK 20 (Accessory)

## Ordering Data

Indexing table ZR 20  
Item no.: 260300 0000

## Accessory

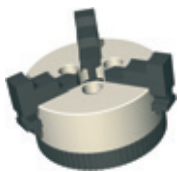

### Chuck

3-jaw chuck Ø 65  
Item no.: 269060 2065



### Collets Fitting

Collets fitting SK 20 for tools Ø 3-10 mm, with mounting ring  
Item no.: 239122 0001

for tools Ø 3-12.7 mm, with mounting ring  
Item no.: 239122 9001

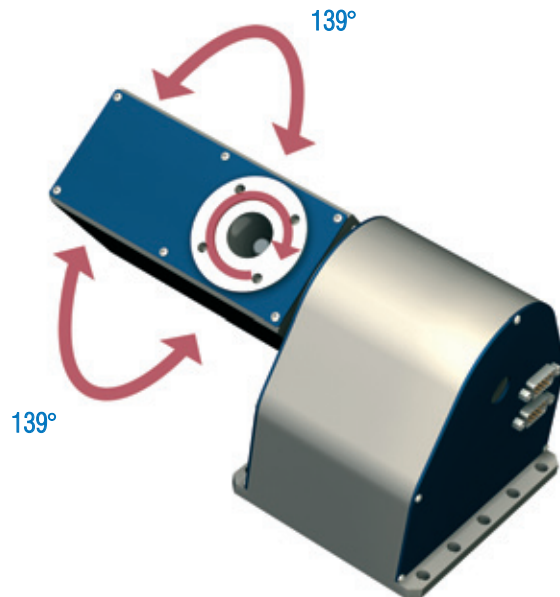

The rotary/swivelling unit ZDS 2030 can be used as fourth/fifth axis in CNC machines in the fields of precision engineering or handling. It is a combination of ZD 30 and the modified version of ZR 20.

The ZDS 2030 enables a conventional 3-axis plant to treat five sides and/or free-form surfaces of easy to machine materials (e.g. plastics). The pivoting angle is 139° in both directions.

Rotary/swivelling unit ZDS 2030  
Item no.: 265 000 0000

## Indexing Table

## ZR 20

## Technical Data

		Stepping Motor MS 045 HT *
Reduction ratio		1:20
Drive revolution	[1/min]	0 - 60
Operating moment (0 - 1600 Hz)	[Nm]	8
Nominal holding torque (static load)	[Nm]	14
Min. increment (positioning accuracy)	[arcmin]	3,5

\* Values at half-step operation

## Scale Drawing

